

CSCI 4360/6360 Data Science II

# Recurrent Neural Networks

# The Neural Network Zoo

- <http://www.asimovinstitute.org/neural-network-zoo/>

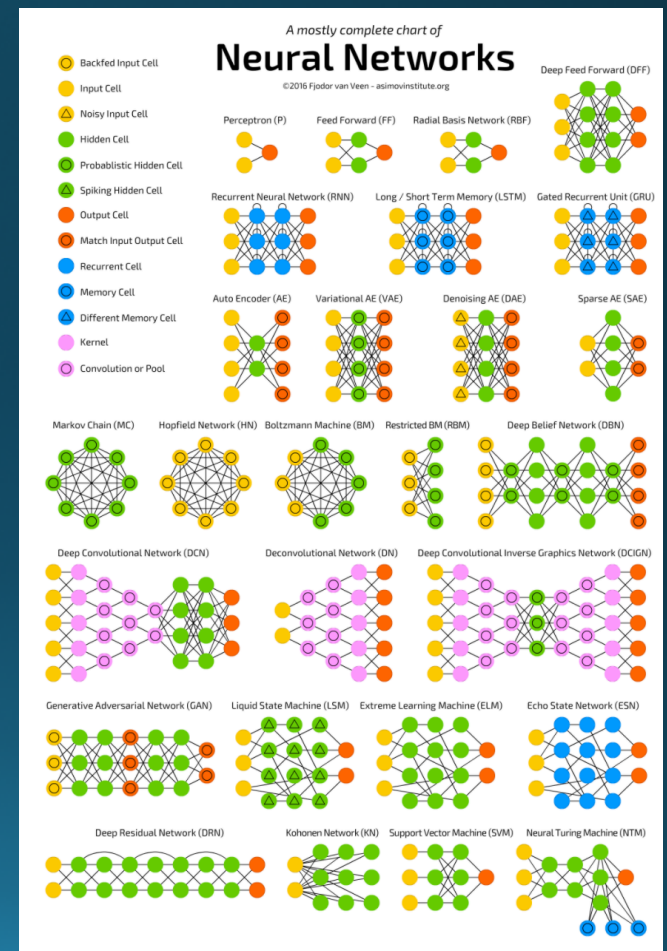

# The Neural Network Zoo

- <http://www.asimovinstitute.org/neural-network-zoo/>

Last time

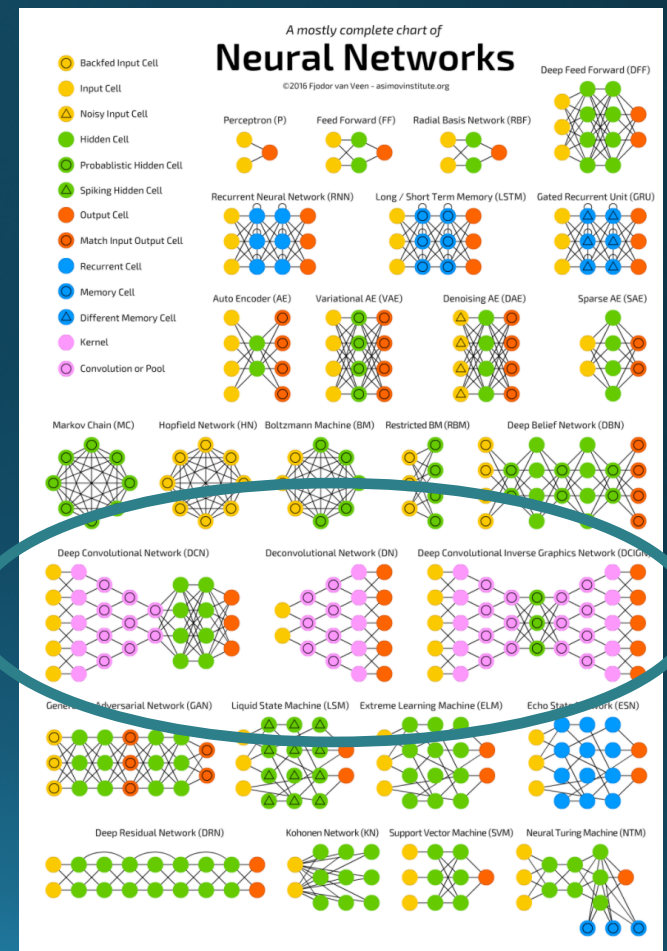

# The Neural Network Zoo

- <http://www.asimovinstitute.org/neural-network-zoo/>

Today

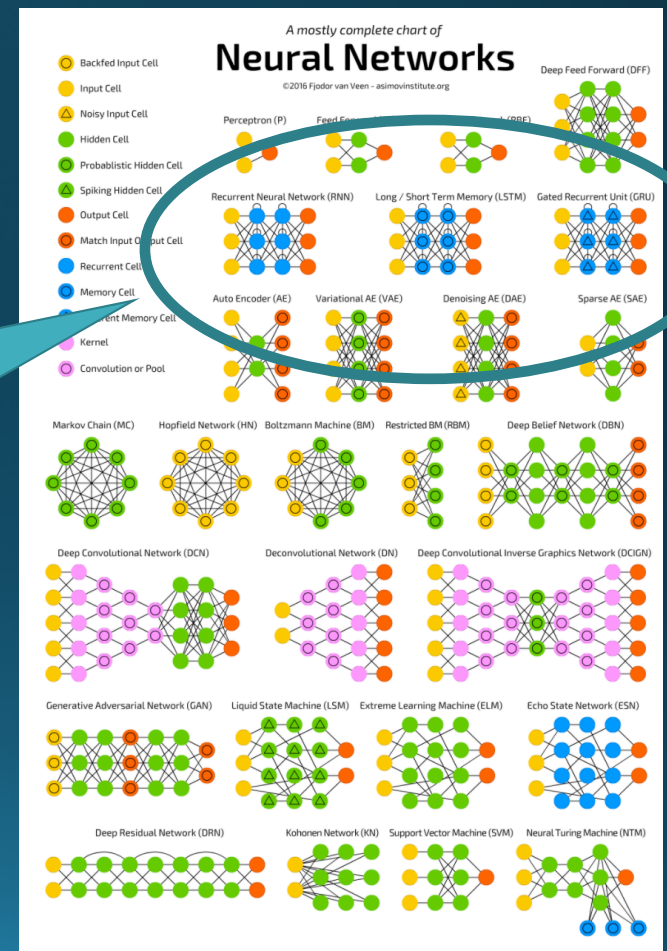

# Modeling Sequences

- Input:

$$X = [\vec{x}_1, \vec{x}_2, \dots, \vec{x}_T]$$

- Output:

$$Y = [\vec{y}_1, \vec{y}_2, \dots, \vec{y}_N]$$

$T$  and  $N$  not necessarily equal

Dimensions of  $X$  and  $Y$  not necessarily equal

Language Translation

Weather and Climate  
Forecasting

Automated Driving

Other "long-distance" time series data

Something we've seen before

# Linear Dynamical Models

- Two main components (using notation from Hyndman 2006):

Appearance  
Model

$$y_t = Cx_t + u_t$$

State Model

$$x_t = Ax_{t-1} + Wv_t$$

# Autoregressive Models

- This is the definition of a 1<sup>st</sup>-order autoregressive (AR) process!

$$x_t = Ax_{t-1} + Wv_t$$

- Each observation ( $x_t$ ) is a function of previous observations, plus some noise
- **Markov model!**



# Autoregressive Models

- AR models can have higher orders than 1
- Each observation is dependent on the previous  $d$  observations

$$x_t = A_1 x_{t-1} + A_2 x_{t-2} + \dots + A_d x_{t-d} + W v_t$$

# Autoregressive Models

- Concrete, *a priori* definition of what is important
  - $n^{\text{th}}$ -order Markov process
  - $n+1$  terms and larger are explicitly ignored
- No concept of *attention*
  - All  $n$  terms receive equal “attention” (computationally, if not also statistically)
  - Are you devoting equal time reading every word on this slide?
- Cannot handle *variable-length inputs*, nor *variable-length outputs*
  - Contrast with CNNs: all input images have to be the same size (usually)
  - Contrast with [insert deep network of choice]: all outputs are the same, given any input

# Attention

- Some things are more important than others

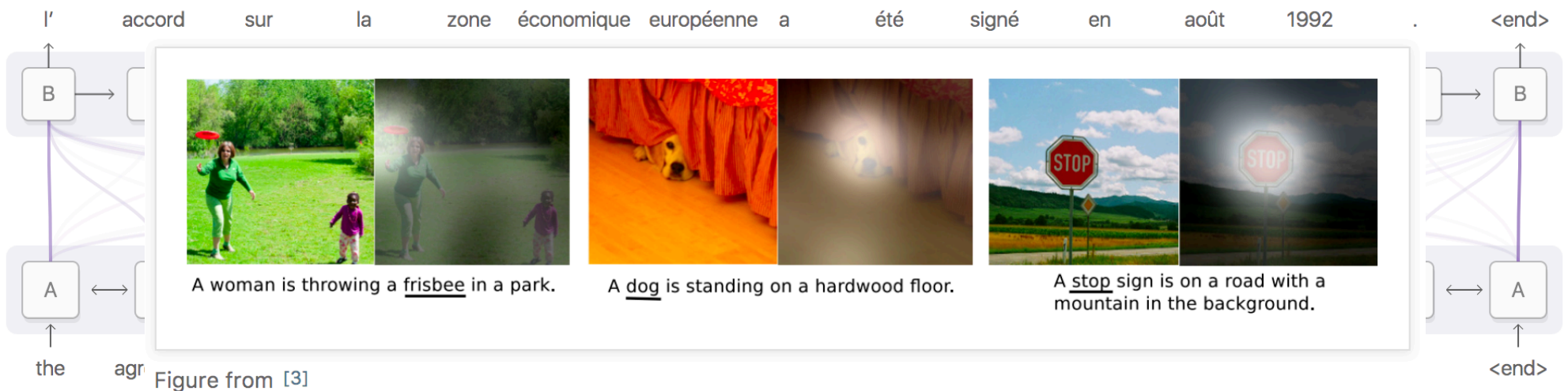
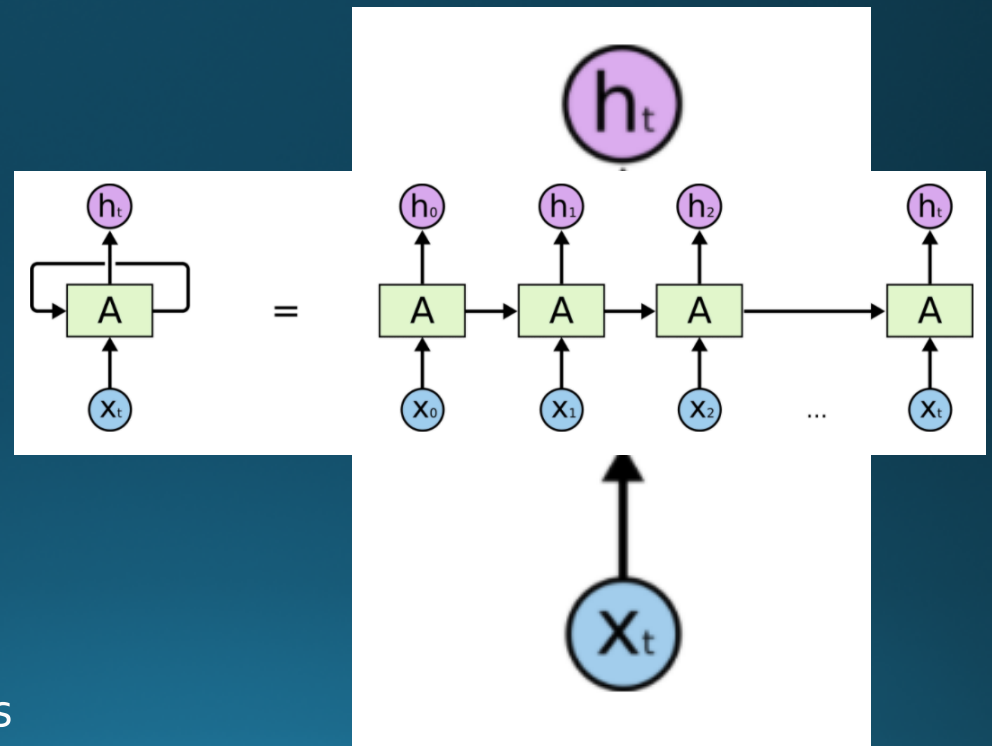

Diagram derived from Fig. 3 of [Bahdanau, et al. 2014](#)

# Recurrent Neural Networks

- In short, recurrent neural networks (RNNs) break the typical “directed acyclic” pedagogy of deep networks by introducing self-loops
  - Allows information to persist through multiple iterations
- We can get around problems introduced by loops by “unrolling” the loops
  - This permits backprop to work as usual



# Recurrent Neural Network

- “List” structure intrinsically handles variable-length data

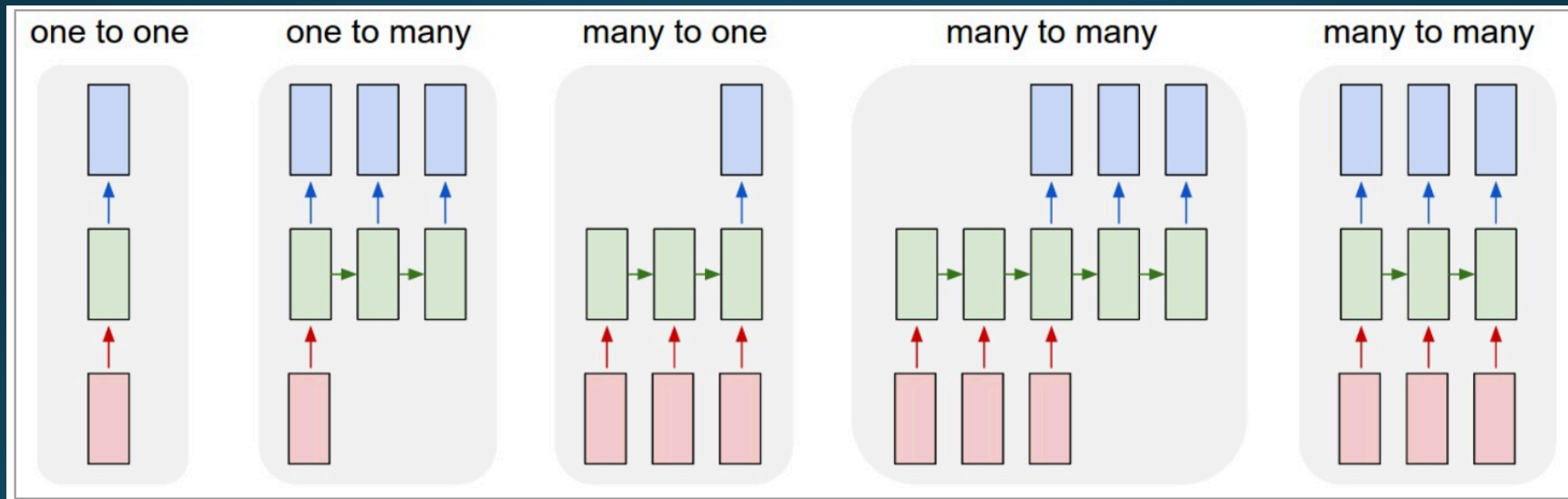

- Think: convolution, but over time instead of space

# Recurrent Neural Networks

- Use the same “parameter sharing” as CNNs
  - And linear dynamical systems!

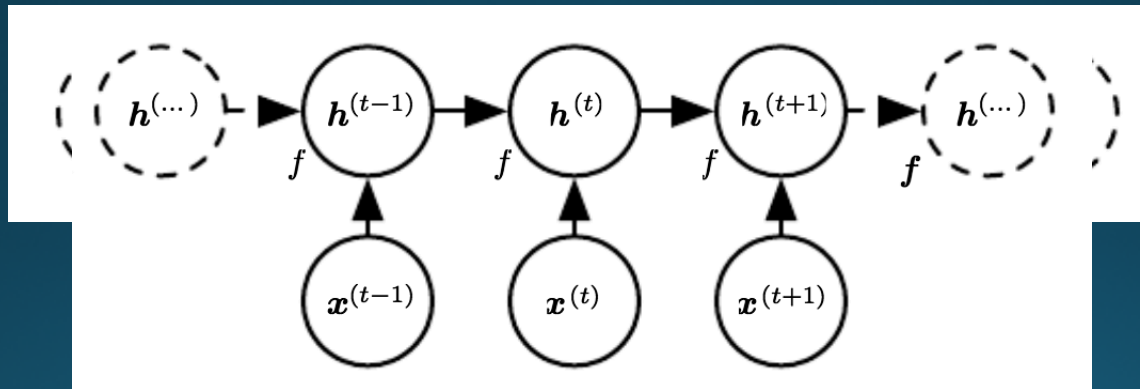

- $f$  maps each time point to the next
- Also updates internal state  $h$

# Recurrent Neural Networks

- Four main equations at each time point

$$\vec{a}^{(t)} = \vec{b} + W\vec{h}^{(t-1)} + U\vec{x}^{(t)}$$

$$\vec{h}^{(t)} = \sigma(\vec{a}^{(t)})$$

$$\vec{o}^{(t)} = \vec{c} + V\vec{h}^{(t)}$$

$$\hat{y}^{(t)} = \phi(\vec{o}^{(t)})$$

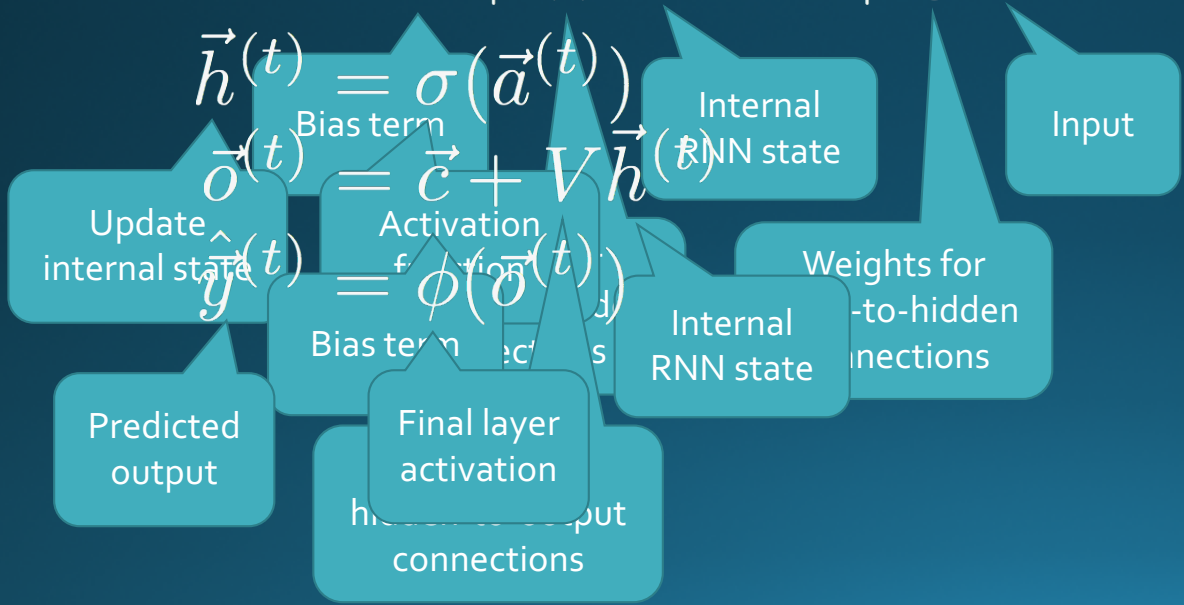

# Recurrent Neural Networks

- RNNs are great for modeling sequences, but by themselves cannot capture *attention*
- **Long-term dependencies require an explicit “memory”**



# Long-term Dependencies

- RNNs *compose* the same activation function repeatedly
  - Think: recurrence relations
- Results in highly nonlinear behavior

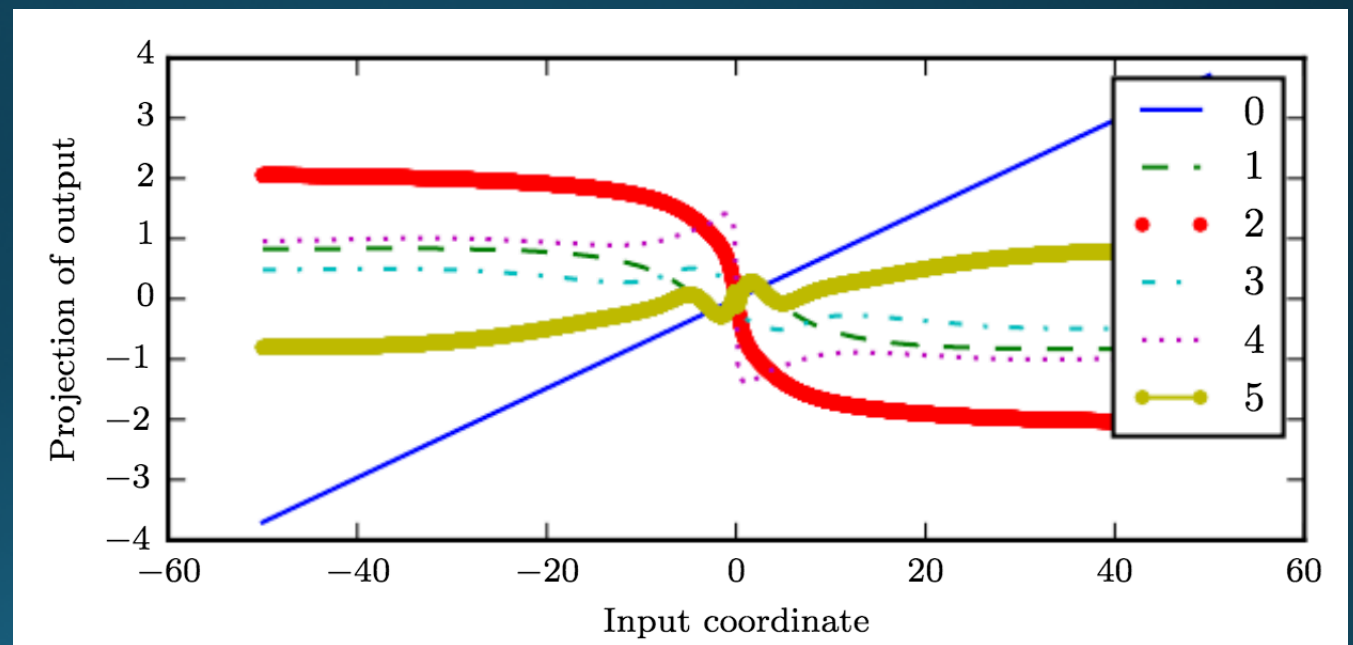

# Long-term Dependencies

- Put another way, recall the internal state update:

$$\vec{h}^{(t)} = W^T \vec{h}^{(t-1)}$$

- Where have we seen this before...

$$\vec{h}^{(t)} = (W^t)^T \vec{h}^{(0)} \quad W = X \Lambda X^T$$

$$\vec{h}^{(t)} = X^T \Lambda^t X \vec{h}^{(0)}$$

- Eigenvalues are raised to the power  $t$ , decaying any eigenvalue  $< 1$
- **Any component of  $h^{(0)}$  not aligned with largest eigenvalue will be discarded**

# Long-term Dependencies

- “I grew up in France... I speak fluent **French**.”

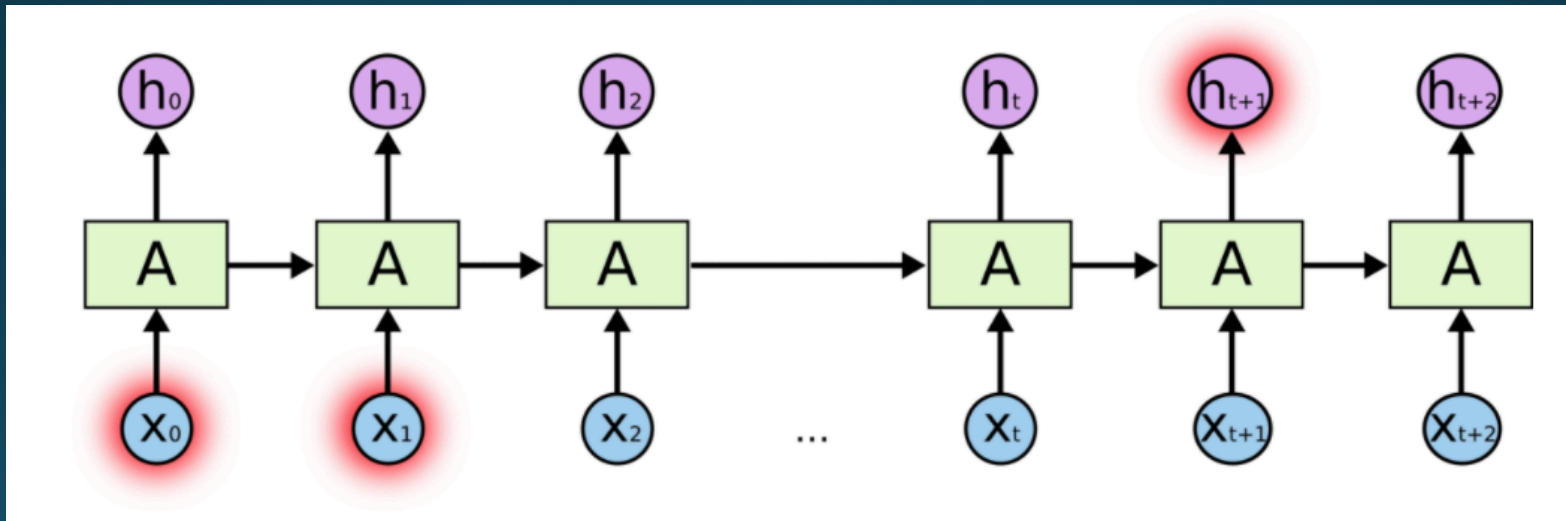

# Long-Short Term Memory

- Or “LSTM”
- A variant of the *gated* RNN
- Each hidden state comprises a **forget gate**
  - Determines what to “remember” and what to discard
  - Functions on self-loop input

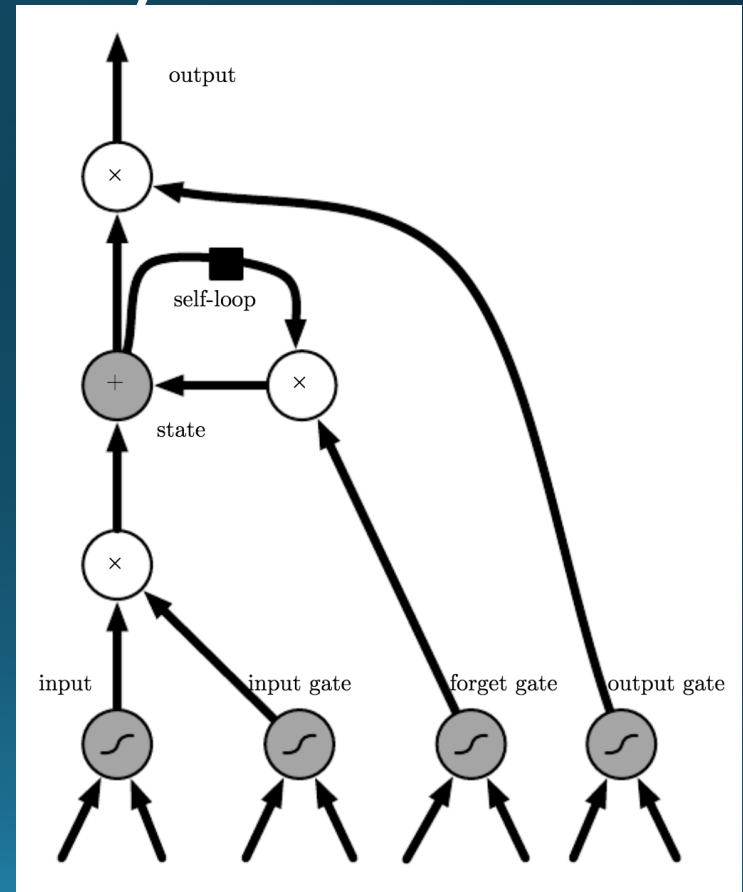

# LSTM versus “vanilla” RNN

- A “vanilla” RNN contains only a single activation
- LSTMs have four interacting layers in each step

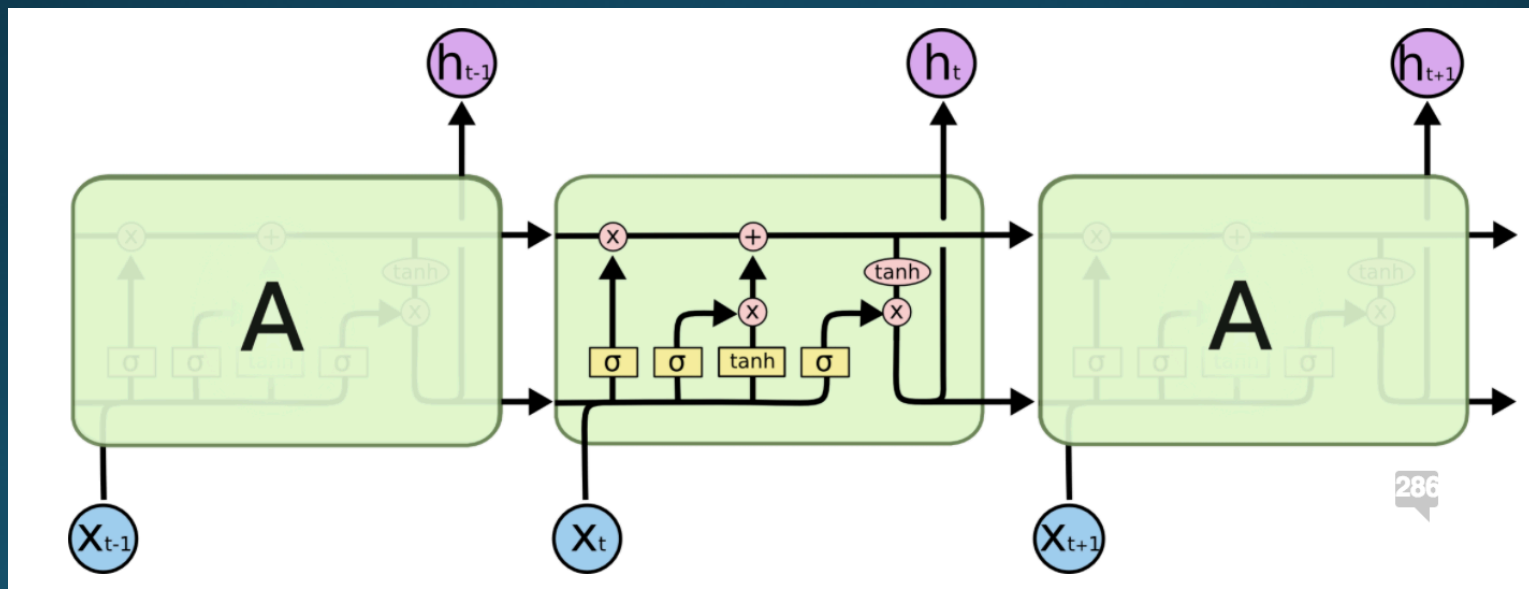

# Other RNN Variants

# Encoder-Decoder Networks

- Maps input to output sequences
  - Each mapping not necessarily of equal length!
- $C$  is a “semantic summary”
  - Think: input “subspace”
- Have to ensure  $C$  is of sufficient dimensionality to represent input space

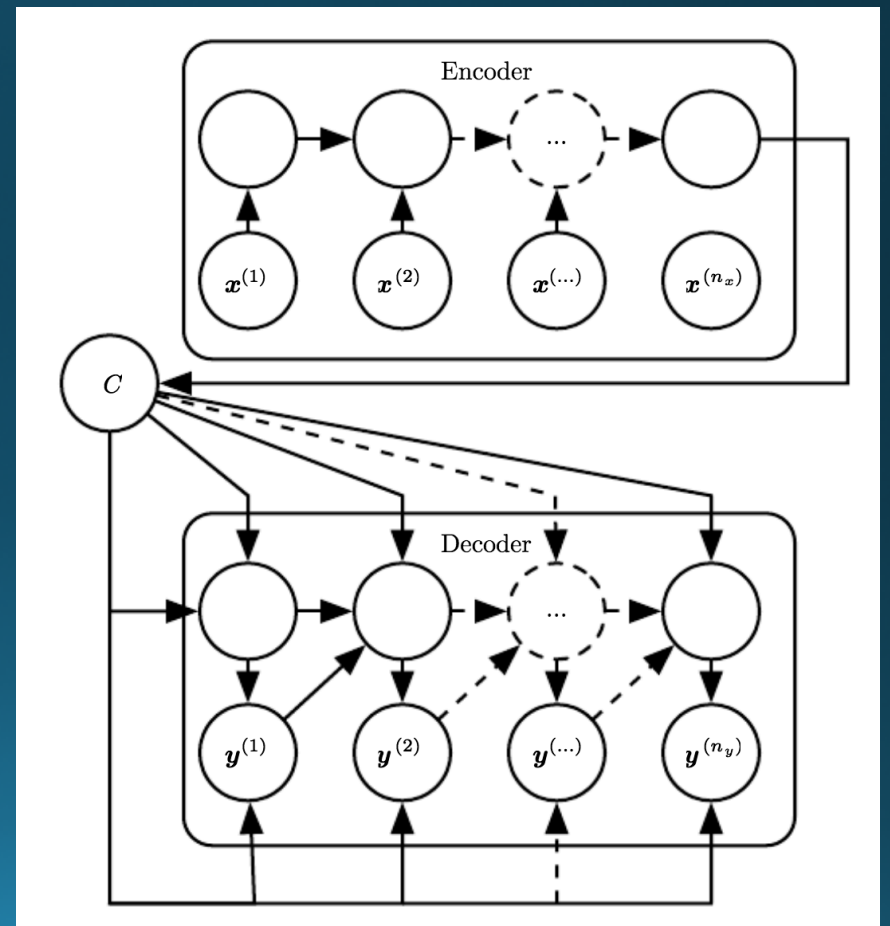

# Deep Recurrent Networks

- Each recurrent state can feed into a series of hidden states
- Analogous to hidden markov models (HMMs) with attention and nearly infinite support for hidden states

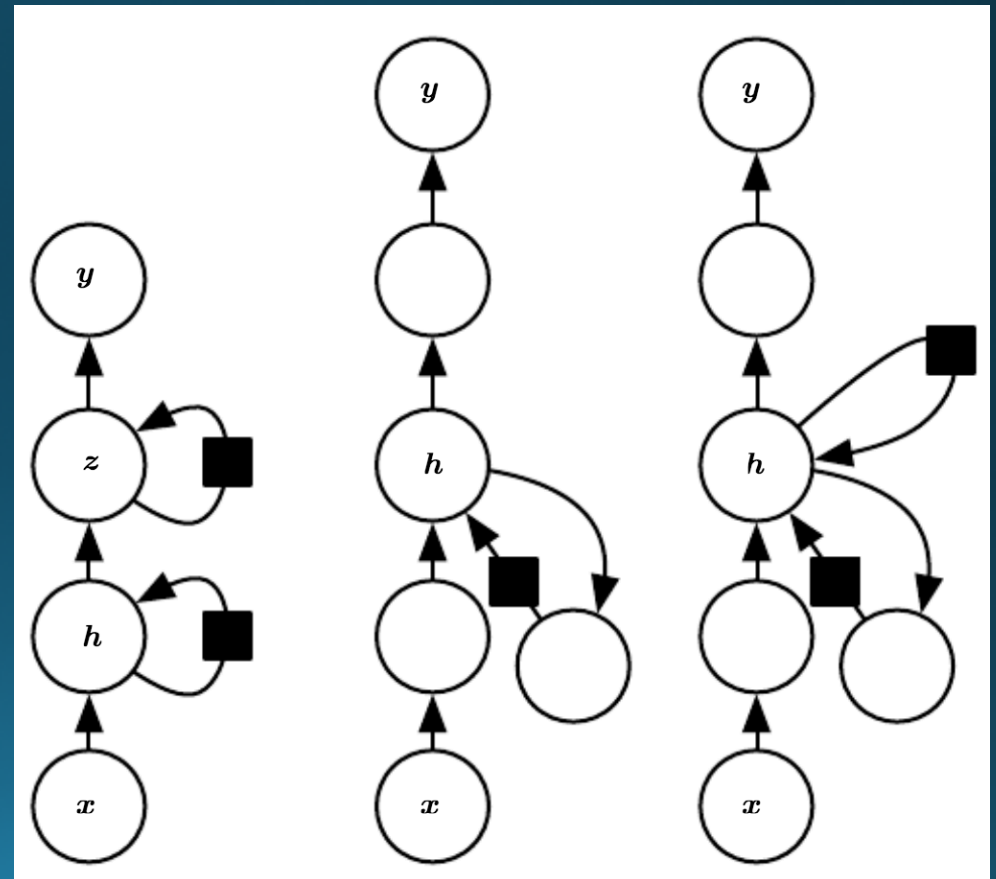



# Conclusions

- Recurrent neural networks
  - A generalization of convolution (or is a convolution a generalization of recurrence?): uses same **parameter-sharing** idea
  - Introduces self-loops, but over discrete intervals: loops can be “unrolled” so backpropagation can still be used as normal
  - Still have trouble with long-term dependencies, such as language translation (vanishing / exploding gradient)
- Long-short term memory
  - Introduce a series of gates within the self-loops
  - Gates determine what to remember, what to discard
  - No ill-conditioned gradients
- Other gated variants

# Course Details

- Projects!
  - 3 presentations per day
  - 9 teams—**20 minutes hard speaking time limit**
  - Presentations are the week after Thanksgiving break
- Already have a few sign-ups!
  - 1 Wed, 2 Thurs
- **First come, first serve!**

Tues,  
11/28

Final Project Presentations

Wed,  
11/29

Final Project Presentations

Thurs,  
11/30

Final Project Presentations

Thurs,  
12/7

*Final Project Deliverables Due*

# References

- Deep Learning Book, Chapter 10: “Sequence Modeling: Recurrent and Recursive Nets”,  
<http://www.deeplearningbook.org/contents/rnn.html>
- “Attention and Augmented Recurrent Neural Networks”,  
<https://distill.pub/2016/augmented-rnns/>
- “Understanding LSTM Networks”  
<https://colah.github.io/posts/2015-08-Understanding-LSTMs/>
- “The Unreasonable Effectiveness of Recurrent Neural Networks”  
<https://karpathy.github.io/2015/05/21/rnn-effectiveness/>